

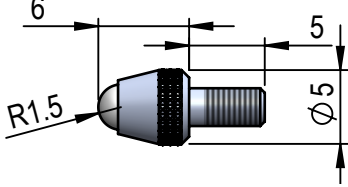





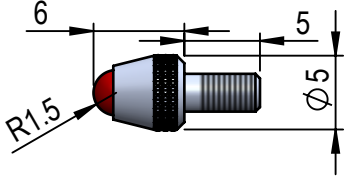

# Messeinsätze M2.5

Messeinsätze mit Anschlussgewinde M2.5 (Zeichnungen Masstab 2:1)

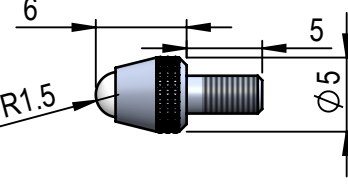
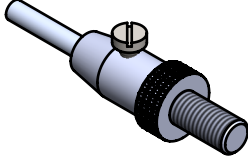
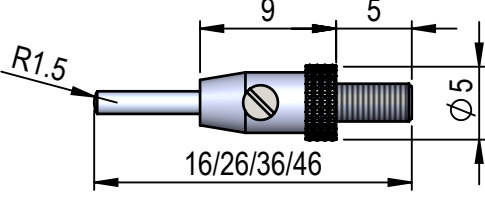
<p>1002449 TN10W</p>		
<p>1003315 Messeinsatz Rubin</p>		
<p>1003313 Messeinsatz PEEK</p>		
<p>1002450 TN12</p>		
<p>1002452 TN20</p>		
<p>1002454 TN30W</p>		
<p>1002456 TN70</p>		

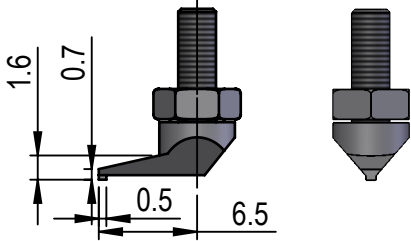
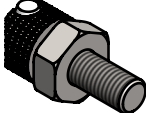
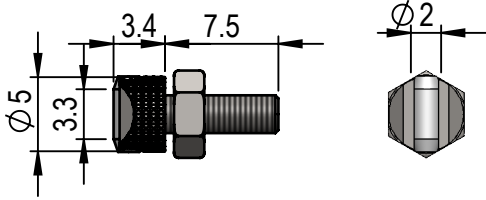
# Messtaster Zubehör

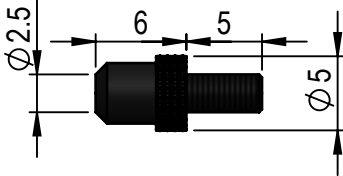
## Messeinsätze mit Anschlussgewinde M2.5 (Zeichnungen Masstab 2:1)

<p>1002458 TN91</p>	
<p>1002460 TN93</p>	

## Befestigungs- und Anschlusselemente (Zeichnungen Masstab 1:1)

<p>1000890 Klemmhülse T100/63000</p>		
<p>1003782 Klemmschraube T100/63100</p>		
<p>1000841 Anschlussnippel rotierend T100/48100</p>		
<p>1002224 Nutenstein T800</p>		

# Verbindungskabel

## Verlängerungskabel Halbbrücke (Zeichnung 1:2)

Kompatibel für TESA(R) Halbbrücken Messtaster

Bestellnummer	Länge
1000916	1.0 m
1000917	2.5 m
1000918	5.0 m
1000919	7.5 m
1000920	10.0 m

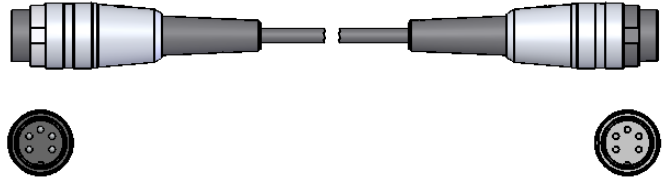

## Anschlusskabel für Messtaster steckbar (Zeichnungen 1:2)

Axialer Kabelabgang

Radialer Kabelabgang

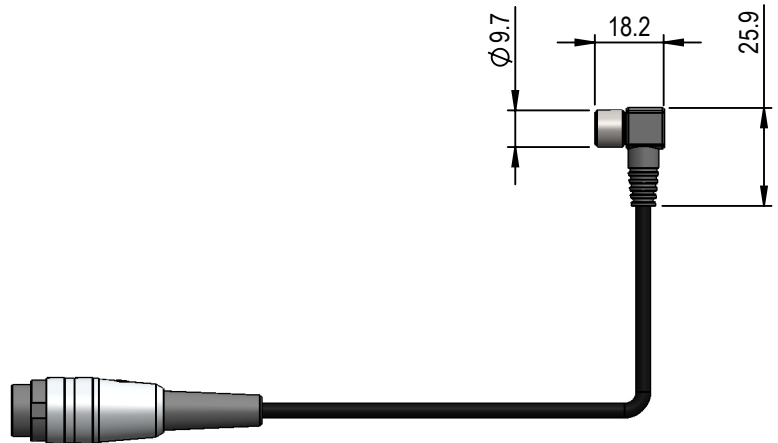
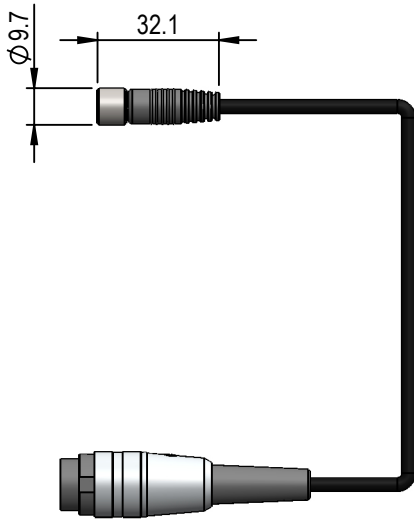

Bestellnummer	Kabelabgang	Länge
1000895	axial	2.0 m
1000896	radial	2.0 m

## Spiralkabel für die steckbaren Messtaster der Serie T070, T100, T200, T300 und T500

1000899

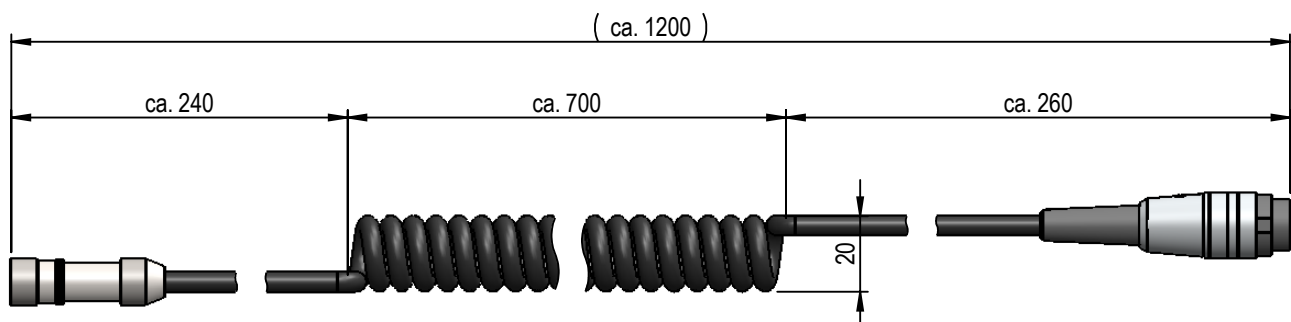

# Messtaster Zubehör

## Andere Federkräfte T100-Serie

Bestellnummer	Federkraft [N]	einsetzbar für
1000921	0.25	T101F, T102F, T101V, T102V, T151F, T152F, T151V, T152V, T161F, T162F, T161V, T162V T100FS, T100VS
1000924	1.00	T101F, T102F, T151F, T152F, T161F, T162F T100FS
1000925	1.60	T101F, T102F, T151F, T152F, T161F, T162F T100FS
1000922	2.50	T101F, T102F, T151F, T152F, T161F, T162F T100FS
1000926	4.00	T101F, T102F, T151F, T152F, T161F, T162F T100FS

## Andere Federkräfte T500-Serie

Bestellnummer	Federkraft [N]	einsetzbar für
1001727	1.60	T501F, T502F, T521F, T522F, T523F, T524F T500FS, T521FS, T523FS T501FDG, T502FDG (nur ab Werk)

## Andere Federkräfte T800-Serie

Bestellnummer	Federkraft [N]	einsetzbar für
1004467	0.40	T801, T802, T851, T852
1004468	0.63	T801, T802, T851, T852
1004469	1.60	T801, T802, T851, T852
1004470	2.00	T801, T802, T851, T852
1004471	2.50	T801, T802, T851, T852
1004472	4.00	T801, T802, T851, T852

## Pneumatikzylinder T800

### 1002214

Pneumatikzylinder T800/88000 für Messtaster der T800 - Serie. Kann für pneumatischen Abhub oder Vorschub verwendet werden. Betriebsdruck ca. 4.5 bar.

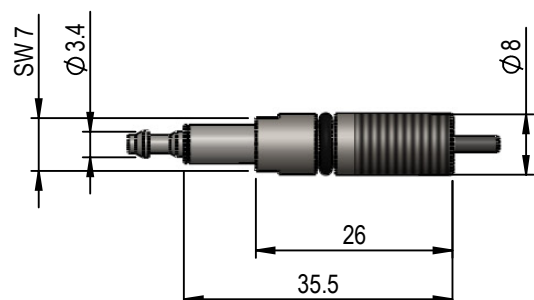

# Halter Messeinsätze T800-Serie

## T800-Serie Halter für Messeinsätze (Zeichnungen 1:1)

### 1003422

Messeinsatzhalter T800 horizontal 4 mm

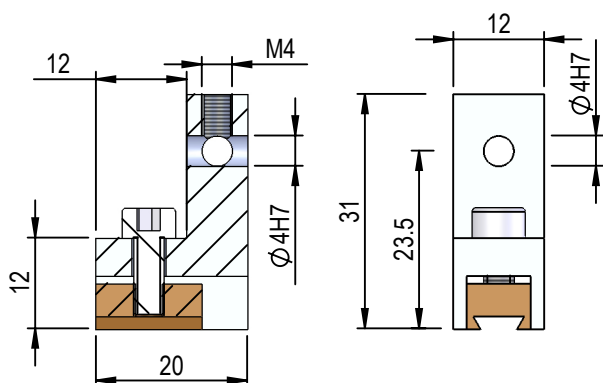

#### bestehend aus

Bestellnummer	Beschreibung
1002218	Halter horizontal 4 mm
1002224	Nutenstein
1003426	Schraube Inbus M4x10

### 1003423

Messeinsatzhalter T800 vertikal 4 mm

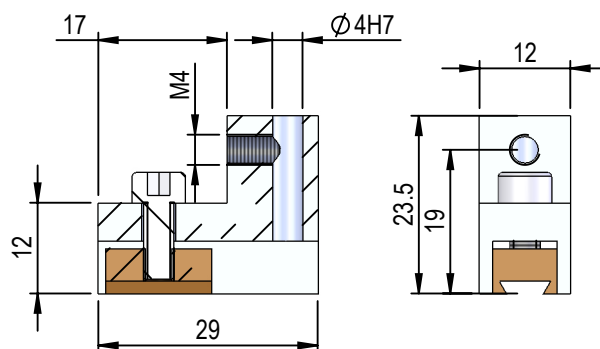

#### bestehend aus

Bestellnummer	Beschreibung
1002219	Halter vertikal 4 mm
1002224	Nutenstein
1003426	Schraube Inbus M4x10

### 1003424

Messeinsatzhalter T800 horizontal 6 mm

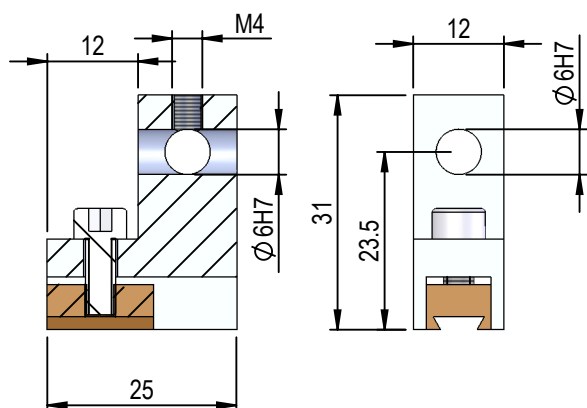

#### bestehend aus

Bestellnummer	Beschreibung
1002220	Halter horizontal 6 mm
1002224	Nutenstein
1003426	Schraube Inbus M4x10

### 1003425

Messeinsatzhalter T800 vertikal 6 mm

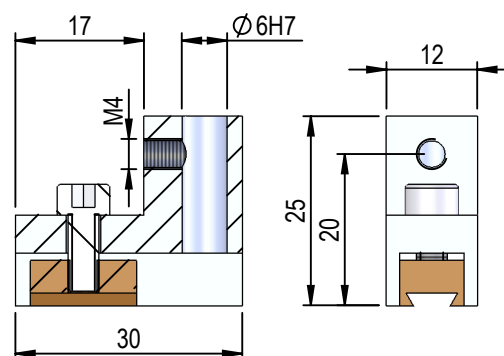

#### bestehend aus

Bestellnummer	Beschreibung
1002221	Halter vertikal 6 mm
1002224	Nutenstein
1003426	Schraube Inbus M4x10